



# JX1

## Kommissionierer

Kommissionierung mit hohem Volumen in einer Lagerumgebung;  
Max Plattformhöhe: 4.80m – Kommissionierhöhe 6.30 m;  
Größe 1590x1500x800, Wenderadius (1385),  
geeignet für schmale Gänge im Lager;  
robust und stabil;  
AGM-Batterie (wartungsfrei), große Blei-Säure-Batterie als Option;  
Einfacher Batteriewechsel.

**EP EQUIPMENT CO.,LTD**  
[www.ep-ep.com](http://www.ep-ep.com)



# Kommissionierer JX1

Kennzeichen	1.1	Hersteller			EP	EP	EP
	1.2	Typbezeichnung des Herstellers			JX1(3200)	JX1(4100)	JX1(4880)
	1.3	Antrieb			Electric	Electric	Electric
	1.4	Bedienung			Order-picker	Order-picker	Order-picker
	1.5	Tragfähigkeit	Q	kg	227/137/136	227*/137/136	227*/137/136
	1.6	Lastschwerpunktabstand	c	mm	-	-	-
	1.8	Lastabstand	x	mm	-	-	-
	1.9	Radstand	y	mm	1150	1150	1256
	Gewichte	2.1	Eigengewicht (inkl. Batterie)		kg	1160	1340
2.2		Achslast mit Last vorn/hinten		kg	680/980	740/1100	780/1220
2.3		Achslast ohne Last vorn/hinten		kg	490/670	520/820	540/990
Räder/Fahrwerk	3.1	Bereifung			Polyurethane/Solid rubber	Polyurethane/Solid rubber	Polyurethane/Solid rubber
	3.2	Reifengröße, vorn		mm	Φ230*75	Φ230*75	Φ230*75
	3.3	Reifengröße, hinten		mm	Φ204*76	Φ204*76	Φ204*76
	3.4	Zusatzräder		mm	Φ74*48	Φ74*48	Φ74*48
	3.5	Räder, Anzahl vorn/hinten (x=angetrieben)		mm	1x,2/2	1x,2/2	1x,2/2
	3.6	Spurweite, vorn	b10	mm	555	555	615
	3.7	Spurweite, hinten	b11	mm	740	740	784
Grundabmessungen	4.2	Eingefahrene Masthöhe	h1	mm	1510	2080	2090
	4.3	Freihub	h2	mm	-	-	-
	4.4	Hub	h3	mm	4030	4930	5710
	4.5	Höhe Hubgerüst ausgefahren	h4	mm	4540	5970	6750
	4.7	Höhe Schutzdach (Kabine)	h6	mm	1590	2120	2120
	4.8	Sitzhöhe bezogen auf SIP/Standhöhe	h7	mm	250	250	250
	4.14	Standhöhe angehoben	h12	mm	3200	4100	4880
	4.15	Höhe gesenkt	h13	mm	-	-	-
	4.19	Gesamtlänge	l1	mm	1500	1500	1610
	4.20	Höhe Hubgerüst eingefahren	l2	mm	-	-	-
	4.21	Gesamtbreite	b1/b2	mm	800	800	860
	4.22	Gabelzinkenmaße	s/e/l	mm	-	-	-
	4.25	Gabelaußenabstand (Abmessung 1), MüG	b5	mm	-	-	-
	4.32	Bodenfreiheit Mitte Radstand	m2	mm	50	50	50
	Leistungsdaten	4.34.1	Arbeitsgangbreite (Palette 1000x1200 quer)	Ast	mm	-	-
4.34.2		Arbeitsgangbreite (Palette 800x1200 längs)	Ast	mm	-	-	-
4.35		Wenderadius	Wa	mm	1385	1385	1450
5.1		Fahrgeschwindigkeit mit/ohne Last		km/ h	5.5/5.5	5.5/5.5	5.5/5.5
5.2		Hubgeschwindigkeit mit/ohne Last		m/s	0.17/0.21	0.17/0.21	0.17/0.21
5.3		Senkgeschwindigkeit mit/ohne Last		m/s	0.35/0.26	0.35/0.26	0.35/0.26
5.8		Max. Steigfähigkeit mit/ohne Last		%	0	0	0
Elektrik	5.10	Beschleunigungszeit mit/ohne Last			Electromagnetic	Electromagnetic	Electromagnetic
	6.1	Fahrmotor, Leistung S2 60 min		kW	1.7	1.7	1.7
	6.2	Hubmotor, Leistung bei S3 15 %		kW	2.2	2.2	2.2
	6.4	Batteriespannung/Nennkapazität K5		V/Ah	24V/224Ah	24V/224Ah	24V/280Ah
	6.5	Batteriegewicht		kg	163	163	250
Zusätzliche Daten	8.1	Art der Fahrsteuerung			AC	AC	AC
	10.5	Lenkungstyp			Electronic	Electronic	Electronic
	10.7	Schalldruckpegel L pAZ (Fahrerplatz)		dB(A)	74	74	74

If there are improvements of technical parameters or configurations, no further notice will be given.  
The diagram shown may contain non-standard configurations.

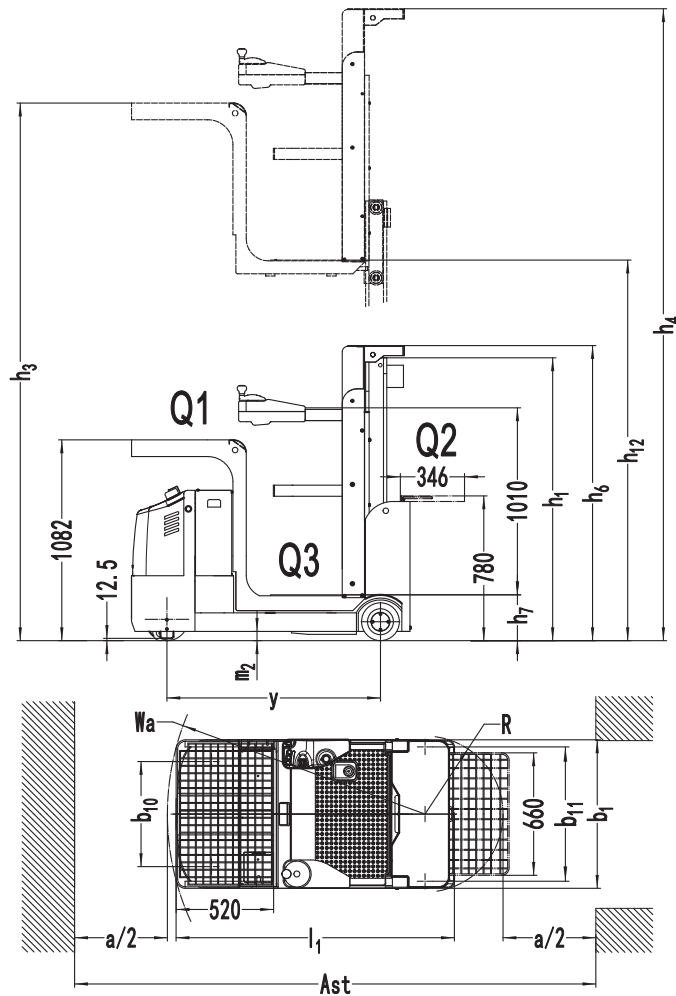

## Optionen

No.	Optionale Elemente	JX1(3200,4100)	JX1(4800)
2.1	Typ Lastrad	●Single	●Single
2.2	Material Lastrad	●Rubber	●Rubber
2.3	Material Lenkrad	●PU	●PU
2.7	Batteriekapazität	○224AH AGM ○210AH Lead-acid ○270AH Lead-acid ○205AH Li-ion	○224AH AGM ○280AH Lead-acid ○360AH Lead-acid ○205AH Li-ion
2.8	Ladegerät	○24V-25A Internal (Only for 224AH AGM battery) ○24V-40A External (Only for Lead-acid battery) ○24V-27.1A Internal (Only for 205AH LI-ion battery)	○24V-25A Internal (Only for 224AH AGM battery) ○24V-50A External (Only for Lead-acid battery) ○24V-27.1A Internal (Only for 205AH LI-ion battery)
2.9	Batterieanzeige	●With time	●With time
2.12	Sicherheitshaken	●No○Yes and not customized	●No○Yes and not customized
2.13	Traktionsbolzen	●No○Yes and not customized	●No○Yes and not customized
2.14	antistatische Kette	●No	●No
3.3	Lenkrollen	●Yes and not customized	●Yes and not customized
3.4	Automatisches Wasserfüllsystem	●No	●No
3.7	Warnlicht	●Front and rear warning lamp ○Front blue light + rear warning lamp ○Front blue light + front warning lamp	●Front and rear warning lamp ○Front blue light + rear warning lamp ○Front blue light + front warning lamp
3.12	Hupe	●Drop buzzer, door alarm buzzer, dip buzzer ○Running buzzer ○Reversing buzzer	●Drop buzzer, door alarm buzzer, dip buzzer ○Running buzzer ○Reversing buzzer
3.18	Führungsrad	●No○Yes and not customized	●No○Yes and not customized
3.19	USB-Schnittstelle	●No○Yes and not customized	●No○Yes and not customized
4.1	Seitlicher Batteriewechsel	●Yes and not customized	●Yes and not customized
4.7	Fahrerschuttdach	●No	●No
5.1	Batterie-Seitenzugbefestigung	●No○Yes and not customized	●No○Yes and not customized

Note: ● standard ○ optional — Inconformity